

THIS DRAWING IS UNPUBLISHED. RELEASED FOR PUBLICATION 20
 © COPYRIGHT 20 BY - ALL RIGHTS RESERVED.

LOC	DIST	REVISIONS					
CM	00	P	LTR	DESCRIPTION	DATE	DWN	APVD
		J		REVISED PER ECO-15-003291	27JULY2015	SC	DZ

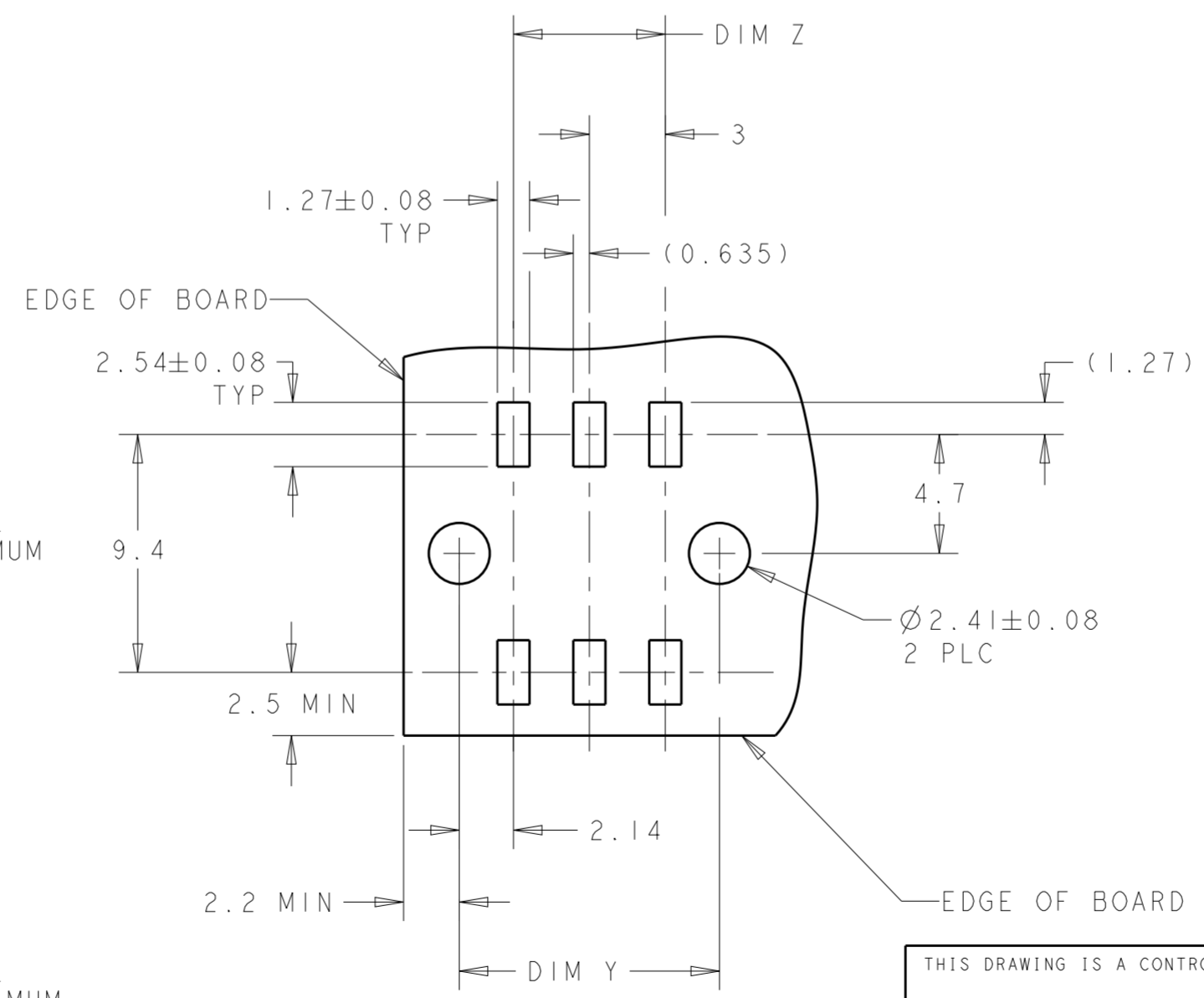
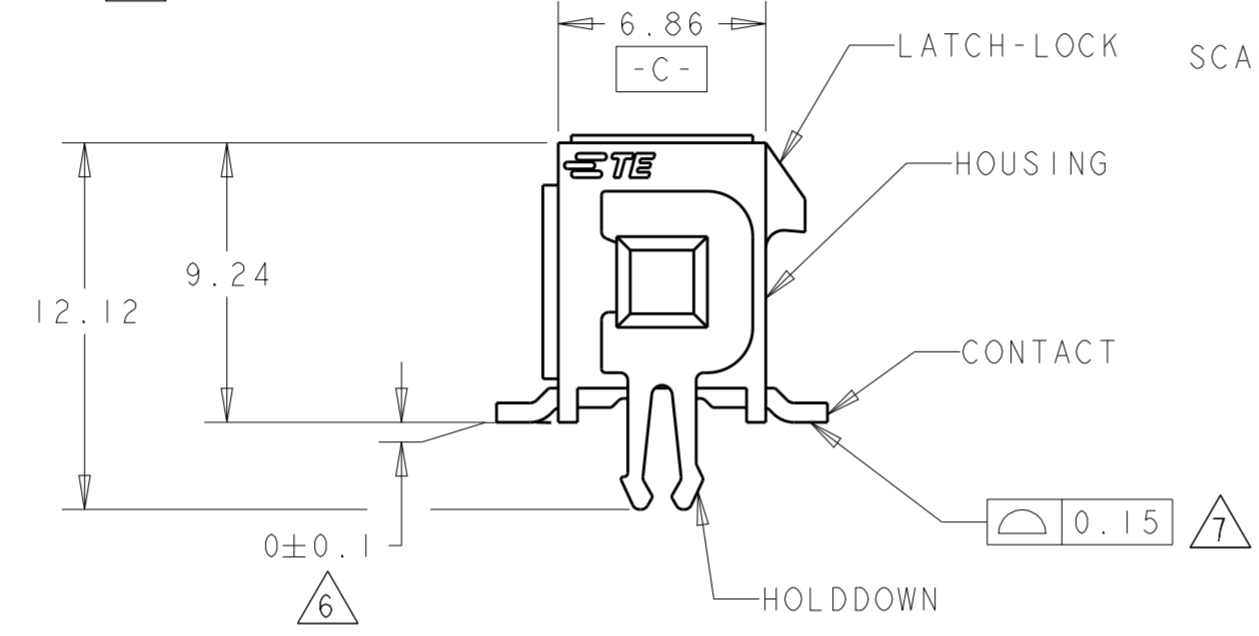
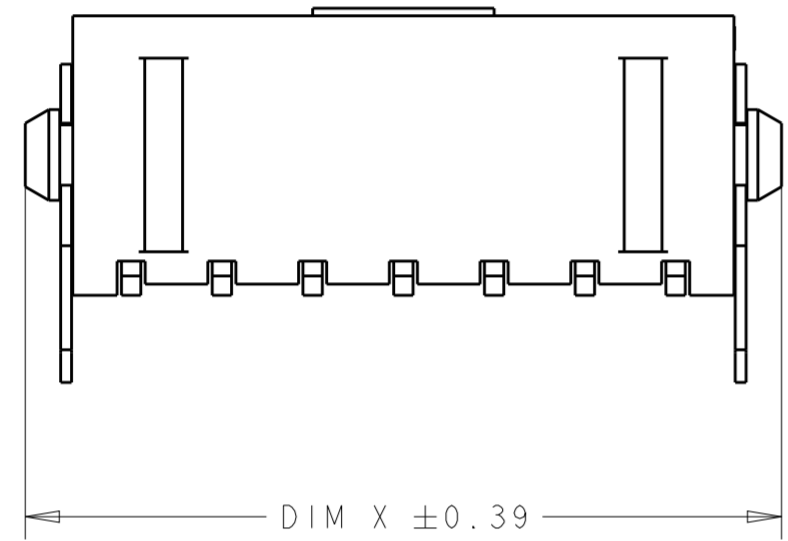
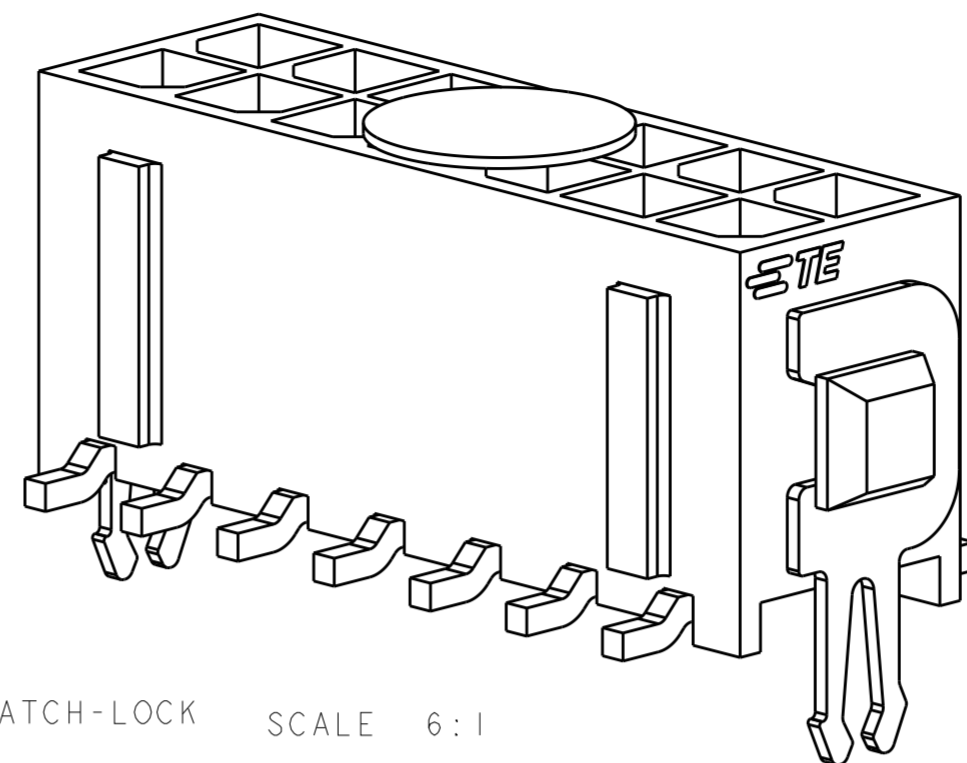
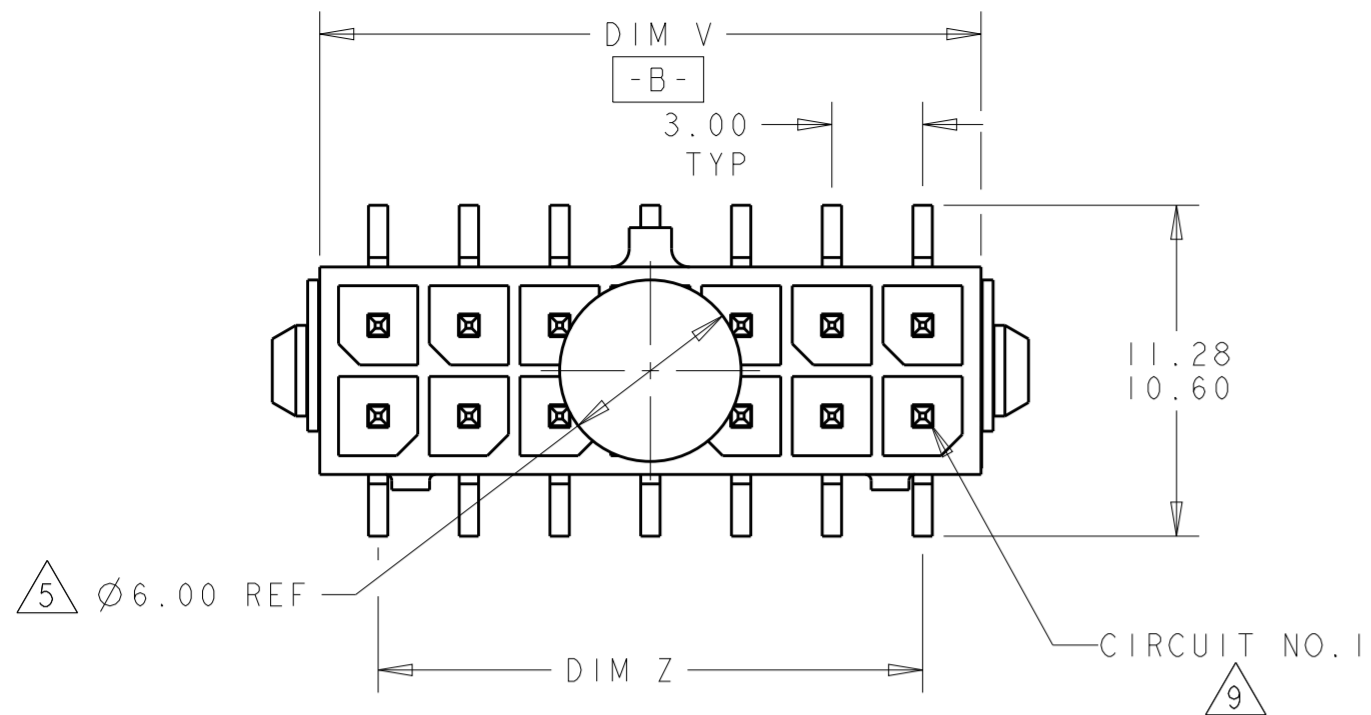

- 1 MATERIAL:
CONTACTS - BRASS.
HOUSING - UL 94V-0 RATED HIGH TEMP NYLON, COLOR; BLACK.
HOLDDOWNS - PHOSPHOR BRONZE.
- 2 PLATING:
CONTACTS - 0.38µm MINIMUM GOLD OVER 2.54µm MINIMUM NICKEL ON MATING AREA. 2.54µm TIN-LEAD MINIMUM OVER 2.54µm MINIMUM ON SOLDER TAILS.
HOLDDOWNS - 2.54µm TIN-LEAD.
- 4 RECOMMENDED PCB BOARD THICKNESS OF 1.57.
- 5 KAPTON VACUUM PICK UP BUTTON.
- 6 DIMENSION APPLIES TO SOLDER TAIL SURFACES AND STANDOFF SURFACES.
- 7 ALL SOLDER TAILS.
- 8 PLATING:
CONTACTS - 0.38µm MINIMUM GOLD OVER 2.54µm MINIMUM NICKEL ON MATING AREA. 2.54µm MATTE TIN MINIMUM OVER 2.54µm MINIMUM ON SOLDER TAILS.
HOLDDOWNS - 2.54µm MATTE TIN.
- 9 CIRCUIT NUMBER 1 IS LOCATED AT THE BOTTOM RIGHT WITH THE LATCH-LOCK ON TOP LOOKING INTO THE CAVITIES

FINISH	DIM V	DIM Y	DIM Z	DIM X	NO. OF POSN.	PART NUMBER
8	36.86	37.30	33.00	40.00	24	5-794634-4
8	33.86	34.30	30.00	37.00	22	5-794634-2
8	30.86	31.30	27.00	34.00	20	5-794634-0
8	27.86	28.30	24.00	31.00	18	4-794634-8
8	24.86	25.30	21.00	28.00	16	4-794634-6
8	21.86	22.30	18.00	25.00	14	4-794634-4
8	18.86	19.30	15.00	22.00	12	4-794634-2
8	15.86	16.30	12.00	19.00	10	4-794634-0
8	12.86	13.30	9.00	16.00	8	3-794634-8
8	9.86	10.30	6.00	13.00	6	3-794634-6
8	6.86	7.30	3.00	10.00	4	3-794634-4
8	3.86	4.30	-	7.00	2	3-794634-2
2	36.86	37.30	33.00	40.00	24	2-794634-4
2	33.86	34.30	30.00	37.00	22	2-794634-2
2	30.86	31.30	27.00	34.00	20	2-794634-0
2	27.86	28.30	24.00	31.00	18	1-794634-8
2	24.86	25.30	21.00	28.00	16	1-794634-6
2	21.86	22.30	18.00	25.00	14	1-794634-4
2	18.86	19.30	15.00	22.00	12	1-794634-2
2	15.86	16.30	12.00	19.00	10	1-794634-0
2	12.86	13.30	9.00	16.00	8	794634-8
2	9.86	10.30	6.00	13.00	6	794634-6
2	6.86	7.30	3.00	10.00	4	794634-4
2	3.86	4.30	-	7.00	2	794634-2

THIS DRAWING IS A CONTROLLED DOCUMENT.

DIMENSIONS: mm

TOLERANCES UNLESS OTHERWISE SPECIFIED:

0 PLC	±
1 PLC	±
2 PLC	±0.13
3 PLC	±
4 PLC	±
ANGLES	±
FINISH	±

MATERIAL: 1 - SEE TABLE

APVD: K. WHITAKER 19MAR2003
 CHK: C. JONES 19MAR2003
 APVD: C. JONES 19MAR2003

PRODUCT SPEC: -
 APPLICATION SPEC: -
 WEIGHT: -

CUSTOMER DRAWING

SCALE: 4:1

SHEET 1 OF 1

REV J

STE TE Connectivity

NAME: SURFACE MOUNT, VERTICAL, MECHANICAL HOLDDOWN, ASSEMBLY, 15 GOLD HEADER, DUAL ROW, MICRO MATE-N-LOK™

SIZE: A2
 CAGE CODE: 0779
 DRAWING NO: C-794634

RESTRICTED TO: -